

P R B X

POWERBOX Industrial Line PAE200W Series Up to 240W 4:1 Single Output DC/DC Converter

Features

No minimum load required
3000vac reinforced insulation for 110Vin
2250vdc basic insulation for 24Vin and 48Vin
UL60950-1, EN60950-1, & IEC60950-1 safety approvals
Compliance to EN50155 and en45545-2 railway standard
Compliance to EN45545-2 fire behavior

Input

Input voltage range	24Vin(nom)	3.3 & 5Vout	9 ~ 36VDC
		Others	8.5 ~ 36VDC
	48Vin(nom)		16.5 ~ 75VDC
	110Vin(nom)		43 ~ 160VDC
Start-up voltage	24Vin(nom)		9VDC max
	48Vin(nom)		18VDC max
	110Vin(nom)		43VDC max
Shutdown voltage	24Vin(nom)		7.3 ~ 8.1VDC
	48Vin(nom)		15.5 ~ 16.3VDC
	110Vin(nom)		33.0 ~ 36.0VDC
Start up time	Power up		75ms typ.
	Remote ON/OFF		75ms typ.
	Constant resistive load		
Input surge voltage	24Vin(nom)		50VDC, 1s max
	48Vin(nom)		100VDC, 1s max
	110Vin(nom)		185VDC, 1s max
Input filter ¹⁾	Pi type		
Remote ON/OFF	Referred to -Vin pin		
	Negative logic DC-DC ON	Short or 0~1.2V	
	(Standard) DC-DC OFF	Open or 3~12V	
	Positive logic DC-DC ON	Open or 3~12V	
	(Option) DC-DC OFF	Short or 0~1.2V	
Input current of Ctrl pin	0.5mA ~ 1mA		
Remote off input current	3mA typ.		
Sync pin signal	-0.3V ~ 5.6V		

Output

Voltage accuracy	±1%	
Line regulation	LL to HL at full load	±0.1
Load regulation	No load to full load	±0.1
Voltage adjustability	-20% min, +10% max. Max output deviation is inclusive of remote sense.	
Remote sense	10% of Vout (nom). If remote sense is not being used, Sense pins should be connected to corresponding polarity OUTPUT pins.	
Ripple and noise	Measured by 20MHz bandwidth.	
	With a 1µF/25V X7R MLCC & a 22µF/25V POS-CAP:	
	3.3Vout, 5Vout	75mV p-p typ
	With a 1µF/25V X7R MLCC & a 22µF/25V POS-CAP:	
	12Vout, 15Vout	100mV p-p typ
With a 4.7µF/50V X7R MLCC:		
24Vout, 28Vout	200mV p-p typ	
With a 2.2µF/100V X7R MLCC:		
48Vout	300mV p-p typ	
Temperature coefficient	±0.02%/°C	



Transient response	25% load step change	200ms typ
Over voltage protection	of Vout (nom); hiccup mode	115~130%
Over load protection	of Iout rated; hiccup mode	120~150%
Short circuit protection	Continuous, automatic recovery.	

Environmental

Operating case temp.	Base-plate	-40°C ~ +115°C
Over temp protection	+120°C	
Storage temperature	Terminal block type	-40°C to +105°C
	Others	-55°C to +125°C
Thermal impedance	Vertical direction by natural convection (20LFM)	
	Module without assembly option	6.1°C/W
	Only mount on the iron base-plate	2.8°C/W
	Heat-sink type with 0.24" height	5.1°C/W
	Heat-sink type with 0.45" height	4.6°C/W
Thermal shock	MIL-STD-810F	
Shock	EN61373, MIL-STD-810F	
Vibration	EN61373, MIL-STD-810F	
Relative humidity	5-95% RH	

General

Isolation voltage	1 minute (reinforced insulation)	
	110Vin(nom) Input to output	3000VAC min
	Input (output) to case	1500VAC min
	1 minute (basic insulation)	
	Others Input to output	2250VDC min
	Input (output) to case	1600VDC min
Isolation resistance	500VDC	1GΩ
Isolation capacitance	2500pF, max.	
Switching frequency	250KHz typ.	
Case material	Metal	24Vin and 48Vin
	Aluminum base-plate with plastic case	110Vin(nom)
Base material	24Vin and 48Vin	FR4 PCB
Potting material	Silicon (UL94 V-0)	
Weight	Module stand alone	105g
	PAE200-□□□□□W-T	235g
	PAE200-□□□□□W-TF	280g
	PAE200-□□□□□W-TF1	287g
MTBF	MIL-STD-217F	2.961 x 10 ⁵ hrs

Standards

Safety approvals	IEC /UL/ EN60950-1 UL:E193009, CB:UL(Demko). EN50155	
Fire behavior	EN45545-2	

POWERBOX Industrial Line
PAE200W Series
 Up to 240W 4:1 Single Output
 DC/DC Converter

EMC Parameter	Conditions	Level
EMI	EN55011, EN55032	PAE200-□□S□□W-TF
		PAE200-□□S□□W-TF1
		Other models; with external components
*Connecting four screw bolts to shield plane will help to reduce the EMI.		
ESD	EN61000-4-2	Air ± 8kV and Contact ± 6kV
Radiated immunity	EN61000-4-3	20V/m
Fast transient	EN61000-4-4	± 2kV
	PAE200-24SW	With 2 pcs of aluminum electrolytic capacitor
	PAE200-48SW	(Nippon Chemi-con KY series, 220μF/100V)
	PAE200-110SW	With 2 pcs of aluminum electrolytic capacitor
Surge	EN61000-4-5	EN55024 ±2kV and EN50155 ±2kV
	PAE200-24SW	With 2 pcs of aluminum electrolytic capacitor
	PAE200-48SW	(Nippon Chemi-con KY series, 220μF/100V)
	PAE200-110SW	With 2 pcs of aluminum electrolytic capacitor
Conducted immunity	EN61000-4-6	10Vr.m.s
Power frequency magnetic field	EN61000-4-8	100A/m continuous; 1000A/m 1 second

Note:

1. Input source impedance: The power module will operate as specifications without external components, assuming that the source voltage has a very low impedance and reasonable input voltage regulation. Highly inductive source impedances can affect the stability of the power module. Since real-world voltage source has finite impedance, performance can be improved by adding external filter capacitor. The PAE200-24SW and PAE200-48SW recommended Nippon Chemi-con KY series, 100μF/100V. The PAE200-110SW recommended Ruby-con BXF series, 68μF/200V. CAUTION: This power module is not internally fused. An input line fuse must always be used

Derating Curve

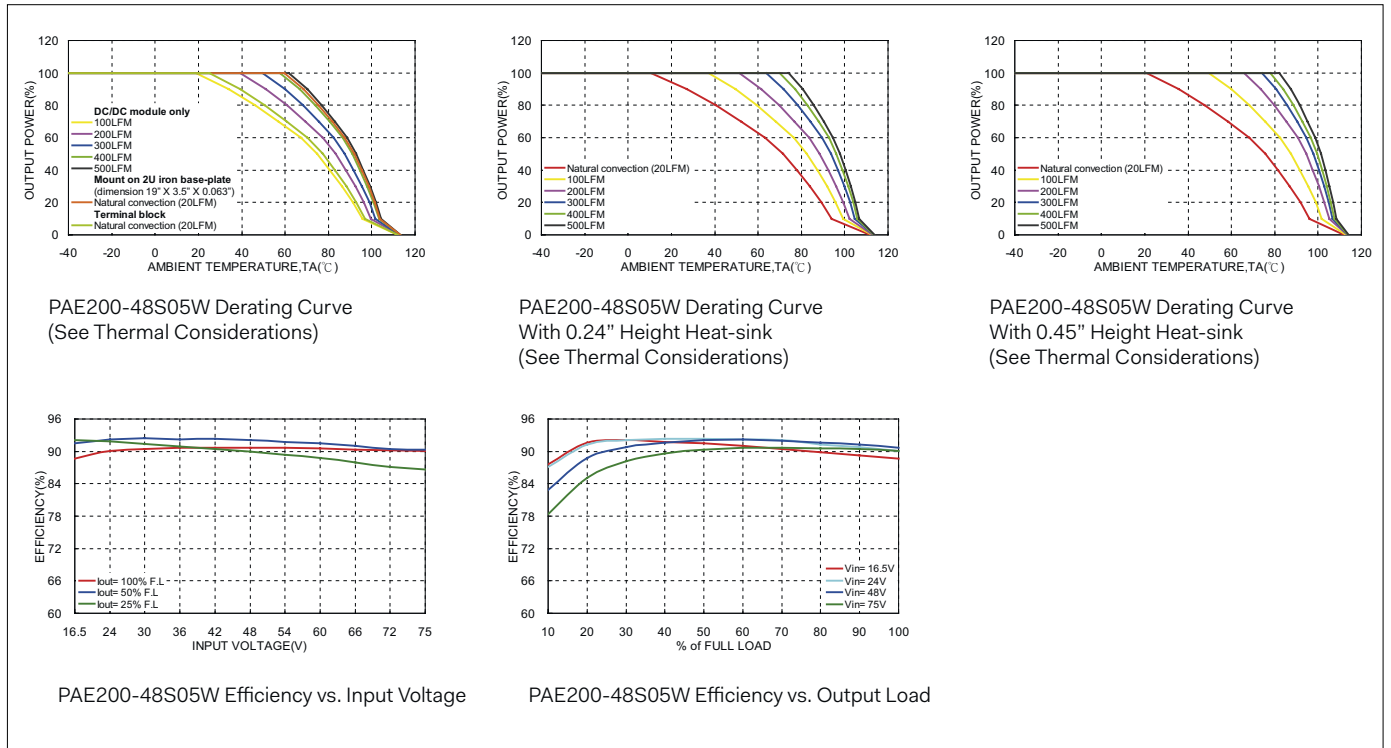

POWERBOX Industrial Line
 PAE200W Series
 Up to 240W 4:1 Single Output
 DC/DC Converter

Model Number	Input Range	Output Voltage	Output Current @Full Load	Input Current @No Load	Efficiency	Max Capacitor Load
PAE200-24S3P3W	9 ~ 36 VDC	3.3 VDC	50 A	25 mA	87%	151000 µF
PAE200-24S05W	9 ~ 36 VDC	5 VDC	36 A	30 mA	90%	72000 µF
PAE200-24S12W	8.5 ~ 36 VDC	12 VDC	15 A	30 mA	89%	12500 µF
PAE200-24S15W	8.5 ~ 36 VDC	15 VDC	12 A	30 mA	90%	8000 µF
PAE200-24S24W	8.5 ~ 36 VDC	24 VDC	7.5 A	35 mA	90%	3100 µF
PAE200-24S28W	8.5 ~ 36 VDC	28 VDC	6.5 A	40 mA	90%	2300 µF
PAE200-24S48W	8.5 ~ 36 VDC	48 VDC	3.7 A	45 mA	89%	770 µF
PAE200-48S3P3W	16.5 ~ 75 VDC	3.3 VDC	50 A	20 mA	88%	151000 µF
PAE200-48S05W	16.5 ~ 75 VDC	5 VDC	40 A	20 mA	91%	80000 µF
PAE200-48S12W	16.5 ~ 75 VDC	12 VDC	18 A	20 mA	90%	15000 µF
PAE200-48S15W	16.5 ~ 75 VDC	15 VDC	14 A	20 mA	91%	9300 µF
PAE200-48S24W	16.5 ~ 75 VDC	24 VDC	9 A	20 mA	90%	3700 µF
PAE200-48S28W	16.5 ~ 75 VDC	28 VDC	7.5 A	25 mA	91%	2600 µF
PAE200-48S48W	16.5 ~ 75 VDC	48 VDC	4.5 A	25 mA	90%	930 µF
PAE200-110S3P3W	43 ~ 160 VDC	3.3 VDC	57 A	10 mA	87%	172000 µF
PAE200-110S05W	43 ~ 160 VDC	5 VDC	44 A	10 mA	89%	88000 µF
PAE200-110S12W	43 ~ 160 VDC	12 VDC	20 A	10 mA	89%	16600 µF
PAE200-110S15W	43 ~ 160 VDC	15 VDC	16 A	10 mA	90%	10600 µF
PAE200-110S24W	43 ~ 160 VDC	24 VDC	10 A	10 mA	89%	4100 µF
PAE200-110S28W	43 ~ 160 VDC	28 VDC	8.5 A	15 mA	90%	3000 µF
PAE200-110S48W	43 ~ 160 VDC	48 VDC	5 A	15 mA	89%	1000 µF

DIP Type

Series Name	Input Voltage	Output Quantity	Output Voltage	Input Range	CTRL and Pin Options	Sync Option	Case Pin Option	Assembly Option
PAE200 - 48	24: 8.5-36VDC 9-36VDC 48: 16.5-75VDC 110: 43-160VDC	S: Single	3P3: 3.3VDC 05: 5VDC 12: 12VDC 15: 15VDC 24: 24VDC 28: 28VDC 48: 48VDC	4:1	<input type="checkbox"/> Negative logic, 0.200" pin length L: Negative logic, 0.145" pin length P: Positive logic, 0.200" pin length S: Positive logic, 0.145" pin length	<input type="checkbox"/> No pin Y: SYNC	<input type="checkbox"/> No pin C: CASE pin	<input type="checkbox"/> None Through hole type TH: No thread Heat-sink type: HS: 7G-0021A-F; H=0.45" HS1: 7G-0022A-F; H=0.24" HS2: 7G-0023A-F; H=0.24" HS3: 7G-0024A-F; H=0.45"

Wall Mounted Type

Series Name	Input Voltage	Output Quantity	Output Voltage	Input Range	CTRL and Pin Options	Assembly Option
PAE200 - 48	24: 8.5-36VDC 9-36VDC 48: 16.5-75VDC 110: 43-160VDC	S: Single	3P3: 3.3VDC 05: 5VDC 12: 12VDC 15: 15VDC 24: 24VDC 28: 28VDC 48: 48VDC	4:1	<input type="checkbox"/> Negative logic, 0.200" pin length P: Positive logic, 0.200" pin length	T: Without EMC filter None TF: Integrated EMC filter and meets EN55032 Class A TF1: Integrated EMC filter and meets EN55032 Class A can be connected to PE

POWERBOX Industrial Line
PAE200W Series
 Up to 240W 4:1 Single Output
 DC/DC Converter

Fuse Consideration

This power module is not internally fused. An input line fuse must always be used. This encapsulated power module can be used in a wide variety of applications, ranging from simple stand-alone operation to an integrated part of sophisticated power architecture. To maximum flexibility, internal fusing is not included; however, to achieve maximum safety and system protection, always use an input line fuse. The input line fuse suggest as below:

Model	Fuse Rating (A)	Fuse Type
PAE200-24S□□W	32	Fast-Acting
PAE200-48S□□W	20	Fast-Acting
PAE200-110S□□W		Fast-Acting

The table based on the information provided in this data sheet on inrush energy and maximum DC input current at low Vin.

Mechanical

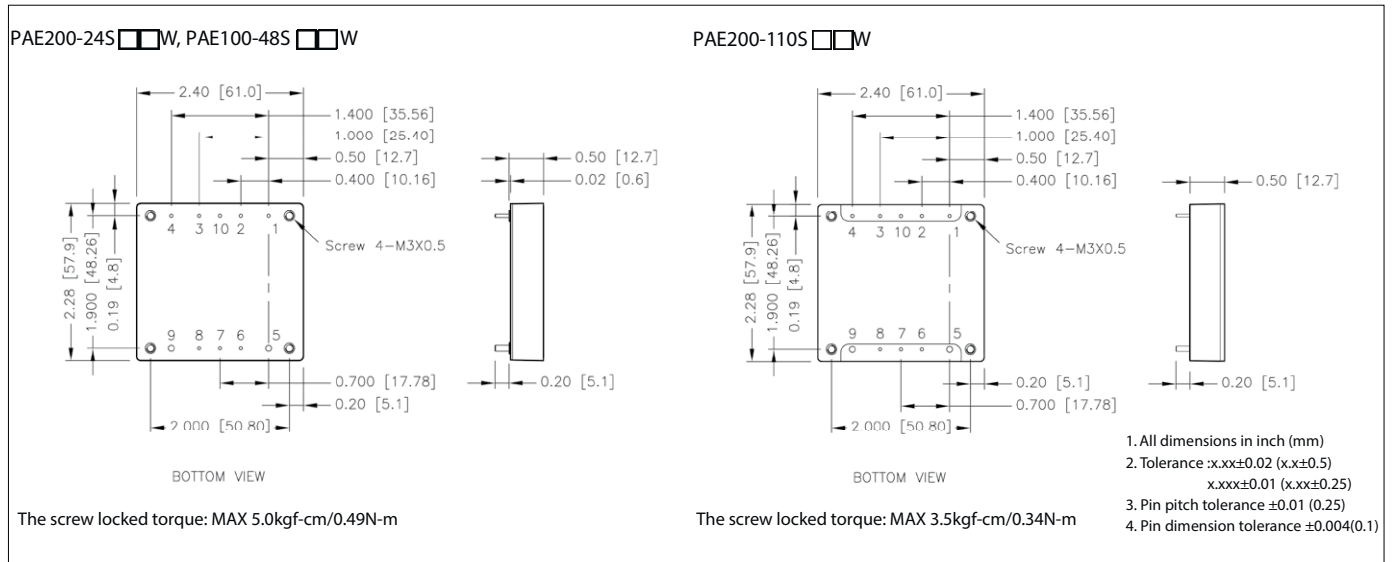

Pin Connection

Pin	Define	Diameter
1	-Vin	0.04 Inch
2	Case (option)	0.04 Inch
3	Ctrl	0.04 Inch
4	+Vin	0.04 Inch
5	-Vout	0.08 Inch
6	-Sense	0.04 Inch
7	Trim	0.04 Inch
8	+Sense	0.04 Inch
9	+Vout	0.08 Inch
10	Sync (option)	0.04 Inch

POWERBOX Industrial Line
PAE200W Series
 Up to 240W 4:1 Single Output
 DC/DC Converter

Terminal Block Option

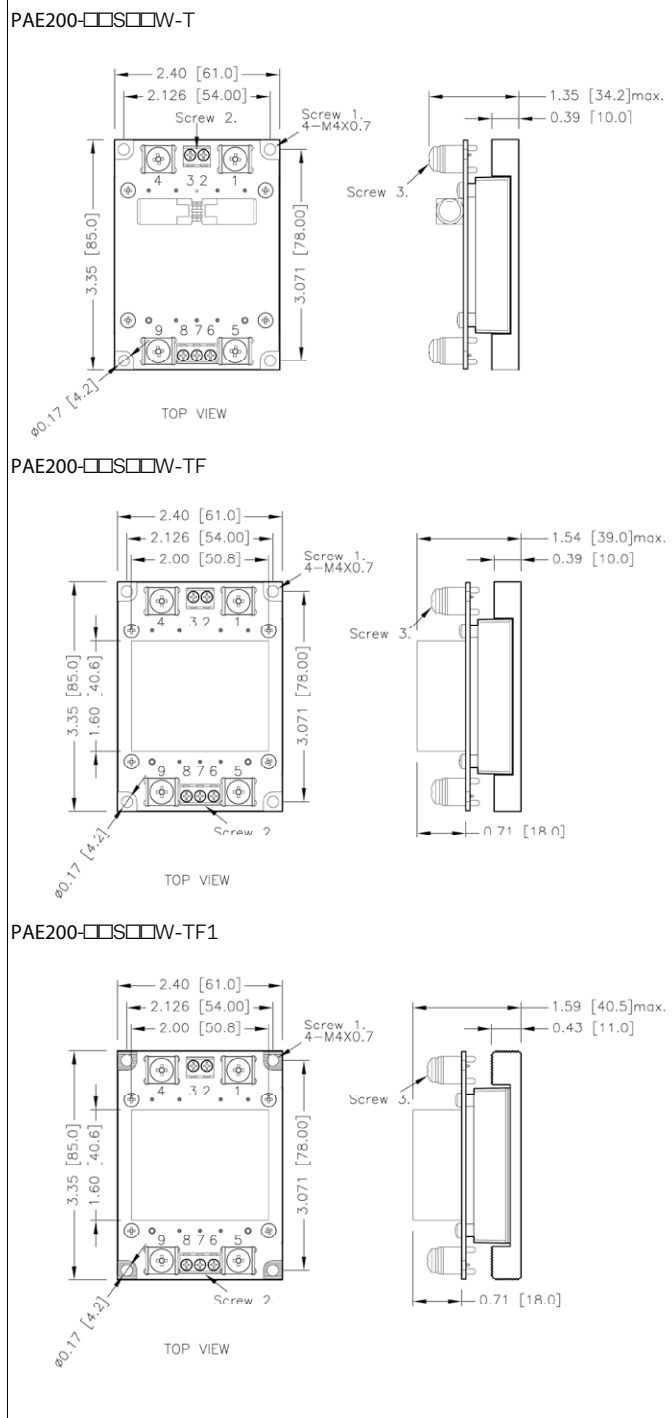

Terminal Connection

Pin	Define
1	-Vin
2	NC
3	Ctrl
4	+Vin
5	-Vout
6	-Sense
7	Trim
8	+Sense
9	+Vout

1. All dimensions in inch [mm]
2. Tolerance :x.xx±0.02 [x.x±0.5]
x.xxx±0.01 [x.xx±0.25]
3. Screw 1 locked torque:
MAX 11.2kgf-cm/ 1.10N-m
4. Screw 2 locked torque:
MAX 5.2kgf-cm/ 0.51N-m
5. Screw 3 locked torque:
MAX 16.8kgf-cm/ 1.65N-m

Recommended Pad Layout

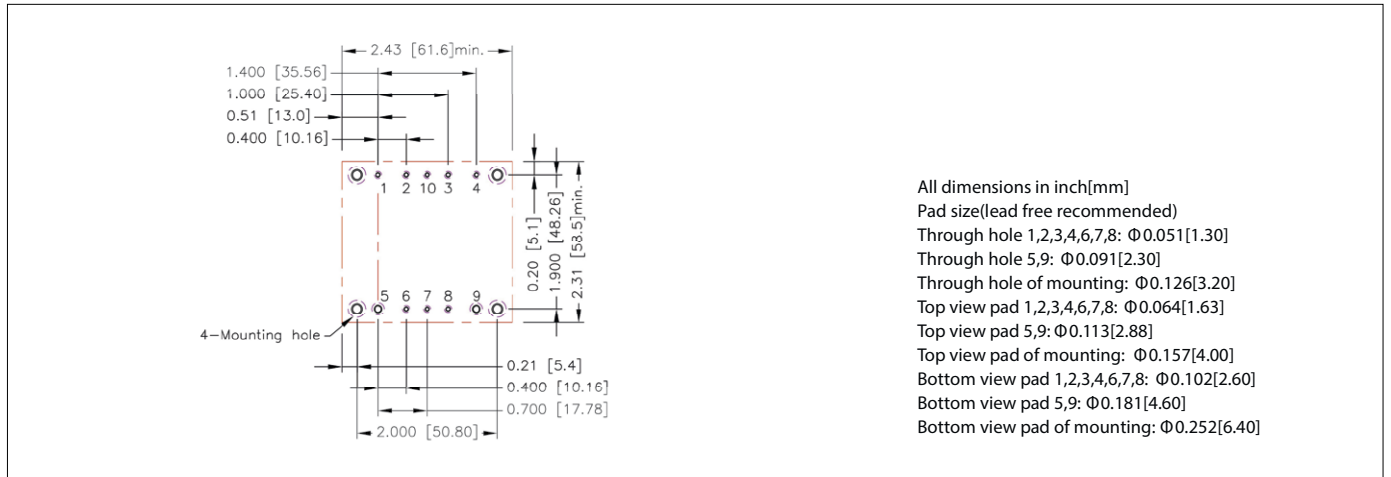

Thermal Considerations

The power module operates in a variety of thermal environments. However, sufficient cooling should be provided to help ensure reliable operation of the unit. Heat is removed by conduction, convection, and radiation to the surrounding Environment. Proper cooling can be verified by measuring the point as the figure below. The temperature at this location should not exceed 105°C. When Operating, adequate cooling must be provided to maintain the test point temperature at or below 105°C. Although the maximum point Temperature of the power modules is 105°C, you can limit this Temperature to a lower value for extremely high reliability. Thermal test condition with vertical direction by natural convection (20LFM). The iron base-plate dimension is 19" X 3.5" X 0.063" (The height is EIA standard 2U). The heat-sink is optional and P/N: 7G-0021A-F, 7G-0022A-F, 7G-0023A-F, 7G-0024A-F.

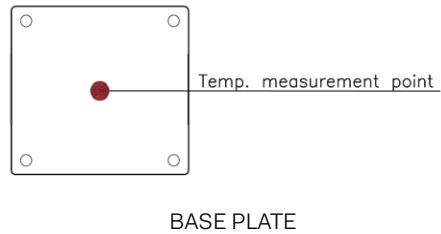

POWERBOX Industrial Line
 PAE200W Series
 Up to 240W 4:1 Single Output
 DC/DC Converter

Heat-Sink Type Options

PAE200-□□S□□W-HS
 7G-0021A-F

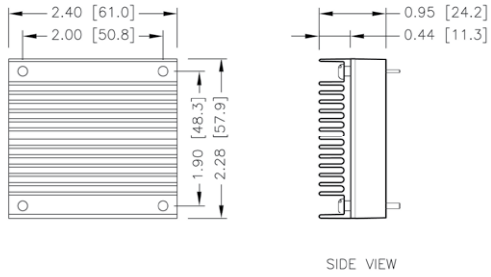

PAE200-□□S□□W-HS1
 7G-0022A-F

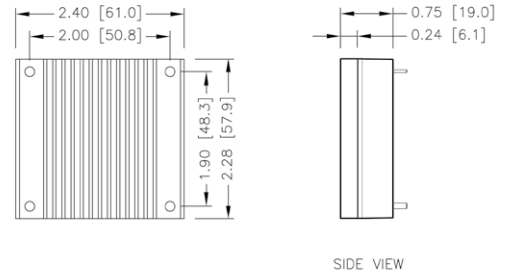

PAE200-□□S□□W-HS2
 7G-0023A-F

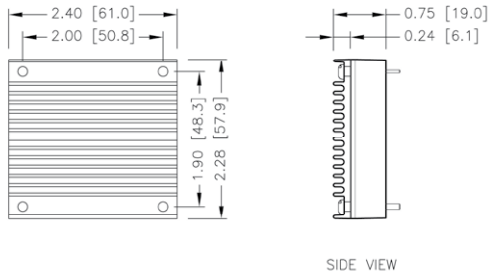

PAE200-□□S□□W-HS3
 7G-0024A-F

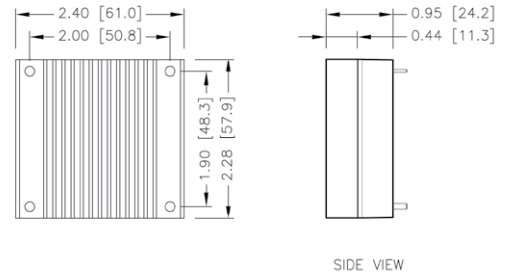

1. All dimensions in inch [mm]
2. Tolerance :x.xx±0.02 [x.x±0.5]
 x.xxx±0.01 [x.xx±0.25]

Output Voltage Adjustment

Output voltage is adjustable for 10% trim up or -20% trim down of nominal output voltage by connecting an external resistor between the Trim pin and either the +Sense or -Sense pins. With an external resistor between the Trim and -Sense pin, the output voltage set point decreases. With an external resistor between the Trim and +Sense pin, the output voltage set point increases. Maximum output deviation is +10% inclusive of remote sense. The external TRIM resistor needs to be at least 1/8W of rated power.

Trim Up Equation

$$R_U = \left(\frac{V_{OUT} (100 + \Delta\%)}{1.225 \Delta\%} - \frac{(100 + 2\Delta\%)}{\Delta\%} \right) k\Omega$$

Trim Down Equation

$$R_D = \left(\frac{100}{\Delta\%} - 2 \right) k\Omega$$

External Output Trimming

Output can be externally trimmed by using the method shown below.

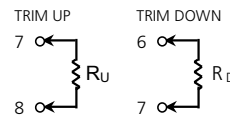

Trim Up

□□S3P3W

ΔV	(%)	1	2	3	4	5	6	7	8	9	10
Vout	(V)	3.333	3.366	3.399	3.432	3.465	3.498	3.531	3.564	3.597	3.630
R _U	(k Ω)	170.082	85.388	57.156	43.041	34.571	28.925	24.892	21.867	19.515	17.633

□□S05W

ΔV	(%)	1	2	3	4	5	6	7	8	9	10
Vout	(V)	5.05	5.10	5.15	5.20	5.25	5.30	5.35	5.40	5.45	5.50
R _U	(k Ω)	310.245	156.163	104.803	79.122	63.714	53.442	46.105	40.602	36.322	32.898

□□S12W

ΔV	(%)	1	2	3	4	5	6	7	8	9	10
Vout	(V)	12.12	12.24	12.36	12.48	12.60	12.72	12.84	12.96	13.08	13.20
R _U	(k Ω)	887.388	447.592	300.993	227.694	183.714	154.395	133.452	117.745	105.528	95.755

□□S15W

ΔV	(%)	1	2	3	4	5	6	7	8	9	10
Vout	(V)	15.15	15.30	15.45	15.60	15.75	15.90	16.05	16.20	16.35	16.50
R _U	(k Ω)	1134.735	572.490	385.075	291.367	235.143	197.660	170.886	150.806	135.188	122.694

□□S24W

ΔV	(%)	1	2	3	4	5	6	7	8	9	10
Vout	(V)	24.24	24.48	24.72	24.96	25.20	25.44	25.68	25.92	26.16	26.40
R _U	(k Ω)	1876.776	947.184	637.320	482.388	389.429	327.456	283.190	249.990	224.168	203.510

□□S28W

ΔV	(%)	1	2	3	4	5	6	7	8	9	10
Vout	(V)	28.28	28.56	28.84	29.12	29.40	29.68	29.96	30.24	30.52	30.80
R _U	(k Ω)	2206.571	1113.714	749.429	567.286	458.000	385.143	333.102	294.071	263.714	239.429

□□S48W

ΔV	(%)	1	2	3	4	5	6	7	8	9	10
Vout	(V)	48.48	48.96	49.44	49.92	50.40	50.88	51.36	51.84	52.32	52.80
R _U	(k Ω)	3855.551	1946.367	1309.973	991.776	800.857	673.578	582.665	514.480	461.447	419.020

Trim Down

□□S□□W

ΔV	(%)	1	2	3	4	5	6	7	8	9	10
R _D	(k Ω)	98.000	48.000	31.333	23.000	18.000	14.667	12.286	10.500	9.111	8.000

ΔV	(%)	11	12	13	14	15	16	17	18	19	20
R _D	(k Ω)	7.091	6.333	5.692	5.143	4.667	4.250	3.882	3.556	3.263	3.000

POWERBOX Industrial Line
 PAE200W Series
 Up to 240W 4:1 Single Output
 DC/DC Converter

Synchronous Pin

Multiple module can be synchronized together simply by connecting the module SYNC pins together.

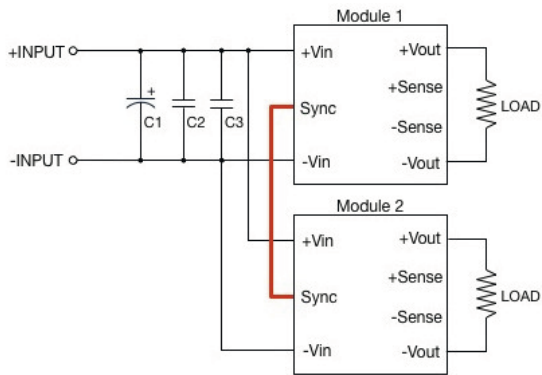

Synchronous Circuits

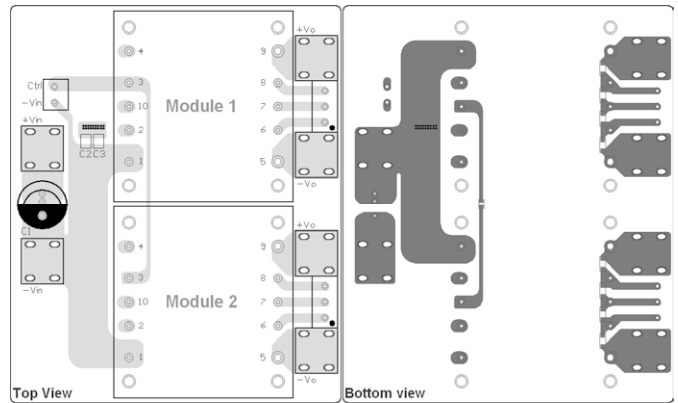

Recommended Layout

PAE200-24S□□W-Y, PAE200-48S□□W-Y

Component	Value	Voltage	Reference
C1	220μF	100V	Nippon chemi-con KY-series
C2, C3	2.2μF	100V	1812 MLCC

PAE200-110S□□W-Y

Component	Value	Voltage	Reference
C1	150μF	200V	Nippon chemi-con KXJ-series
C2, C3	1μF	250V	1812 MLCC

- Care should be taken to ensure the ground potential differences between modules are minimized.
- All of the modules in this configuration will be synchronized to the highest frequency module.
- Up to three modules can be synchronized using this technique.

Specifications are subject to change without notice.