

POWERBOX  
Mastering Power

A Cosel Group  
Company

Transportation  
Automotive

A large yellow mining truck is the central focus, parked on a dirt road at a quarry. The truck is viewed from a low angle, emphasizing its massive size. The background features a dramatic sky with dark, heavy clouds and a bright, golden glow from the setting or rising sun, creating a high-contrast, atmospheric scene. The ground is rocky and uneven, typical of a mining site. In the distance, other mining equipment and structures are faintly visible.

P  
R  
B  
X



# Automotive solutions

## From tunnelling to connected buses

The industrial automotive industry comprises a large segment of diverse applications such as buses, trucks, industrial vehicles, mobile machinery e.g. mining equipment, forklifts, cleaning, automated machines, emergency, and service vehicles, all requiring flexible power solutions. Often deployed in harsh and complex environments, the equipments require robust power supplies that may be exposed to water, diesel fumes, smoke or dirt. So it is very important that they are able to withstand the effects of such aggressive environments. Systems may also be exposed to high levels of vibration and often with little or no ventilation, requiring power supplies to be designed for robustness and with built-in extreme reliability.

Such operating conditions necessitate power supplies to include state of the art power switching technology to reduce power dissipation, coupled with thorough mechanical and thermal designs to ensure reliability and a long life.

From tunnelling equipment to the latest generation of buses equipped with video-on-demand, high speed internet connections and safety monitoring, industrial automotive designers and integrators not only demand high levels of quality, but that suppliers are able to offer products ranging from standard production units to full custom power solutions, able to operate flawlessly in rugged environments.

## From watts to kilowatts

Powerbox has been powering demanding industrial applications for more than 40 years. The more demanding the application, the better the odds are that we can offer you a differentiating advantage in the form of an optimized solution. 'Demanding' might for instance refer to the electrical specification, the environmental conditions, EMC requirements, or maybe the number of outputs. Our solutions range from single output converters to complete systems with multiple outputs, redundancy, back-up, and so on.

Our range of power converters covers AC/DC, DC/AC, and DC/DC with a wide span of voltages and power, from a few watts to many kilowatts. The extensive standard range, comprising a combination of our own designs and products from our leading partners, is complemented by our custom design capabilities, ensuring we can always deliver optimized solutions. We can accommodate virtually any mechanical format and several different cooling principles. Communications interfaces and control software can also be incorporated. Most of all we have a long term approach to customer relations, and working together we create a competitive advantage by means of our optimized power solutions.

## Typical industrial automotive applications

Our extensive experience in powering industrial automotive applications covers many different application areas. Here are just a few examples:

- AGV and forklifts
- Timber vehicles
- Mining vehicles
- Construction vehicles
- Rescue vehicles
- Trucks and buses
- Infotainment

## Standards

The standards that we work to in the automotive industrial sector are ISO7637 and EN12895. However, with 40 years of designing industrial power supplies and systems under our belt, we are experienced in meeting the requirements of a myriad of standards for different types of applications or in different parts of the world. We also closely follow the development of new standards and hence we are well prepared for the new requirements to come, we are a jump ahead.

# Automotive solutions

## Standard products

Our extensive range of standard converters, for automotive applications, comprises of both our own products, designed by our engineers and manufactured at world class manufacturing facilities, as well as products from our leading product partners. After working in the automotive markets for 30+ years chances are good we have a standard power supply to meet your needs.

## Custom products

If a suitable product cannot be found from our standard product range, we can consider providing modified standard, semi or full custom solutions. Our custom design capability and reputation is second to none. We have completed more than 2,500 custom design projects to date, whereof 1,350 at our Gnesta, Sweden, design center.

## Services

The right product is essential, but it is not everything. In addition to product offerings we include a comprehensive range of services, from analysis and qualification in the development stage, demand planning and special logistics in the production phase, to RMA handling and end user support in the after-market. We aim to serve you with simplicity to ensure your customers return time and again.

## Systems

An application might require more than a single converter. We then use our product range and our custom capability to build systems. These can feature multiple standard, semi-custom, and/or full-custom converters, battery backup, communications, remote control, intelligent charging, distribution panels, sub racks, enclosure etc., and maybe also a number of value-added services. We lean confidently on over 40 years of experience and subject matter expertise to identify the best means of solving every particular power conversion challenge. Together with our customers we find the optimized solution.

### Drivers cabin

- Computers
- Displays
- Communication
- Audio/Video
- Control

### Processing

- Lifting
- Drilling
- Crushing
- Planting
- Harvesting

### Electrical System

- Computers
- Sensors
- Charging
- Auxiliary power

### Road Side

- Signage
- Communication
- Fleet management

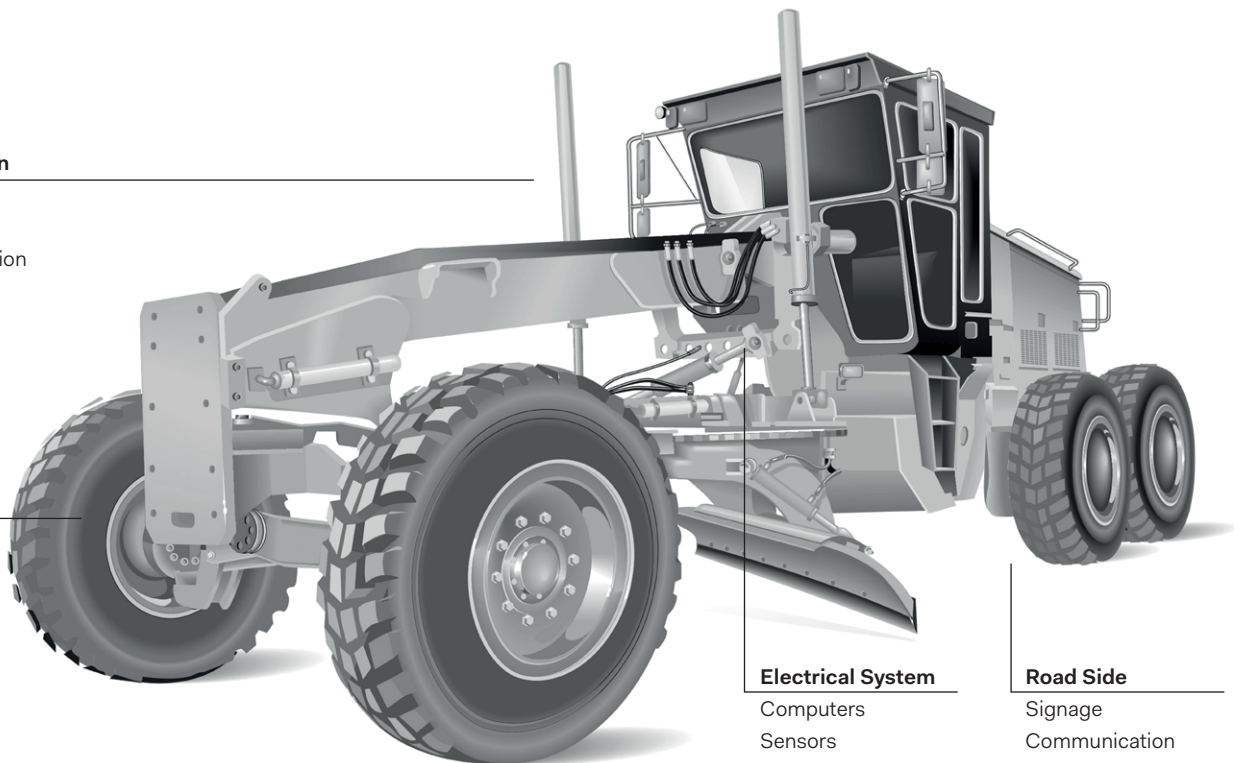

# Standard products – Automotive line



**Automotive line 20-60  
ENA20-60 Series**  
20W, 30W, 40W, 60W  
2:1 or 4:1 single, dual, triple output  
DC/DC Converter



**Automotive line 100  
ENA100 Series**  
100W 2:1 single output  
DC/DC converter



**Automotive line 200  
ENA200 Series**  
200W 2:1 single output  
DC/DC converter



**Automotive line 400  
ENA400-M Series**  
400W single output  
DC/DC converter



**Automotive line 216  
ENA Charger Series**  
216W 2:1 single output  
DC/DC battery charger



**Automotive line  
ENA NI Series**  
60-380W single output  
Non-isolated DC/DC converter



**PAF150(D)150 Series**  
150W, 24V, 48V or 110V input  
DC/DC converter



**ENAR150D Series**  
150W, 24V or 110V input  
2x24V or 2x12V output  
DC/DC converter



**DAA/DAB/DAC Series**  
150W, 300W or 500W, Enclosed,  
rugged design  
12, 24, 48, 72, 110VDC inputs  
Output from 3V3 to 48VDC  
DC/DC converter



**Modules**  
1-60W  
2:1 or 4:1 Input voltage range  
SIP, DIP, 1x1", 1x2", 1.6x2", 2x2"  
DC/DC converter



**Bricks**  
50-750W  
Full, half or quarter  
DC/DC converter

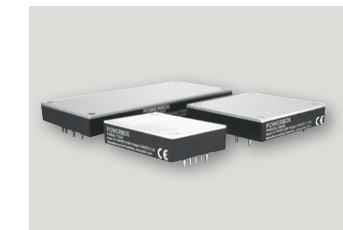

**HVDC bricks**  
150W, 300W, 600W, 750W  
200-400V input  
Full, half or quarter  
DC/DC converter

# Cosel standard products

Established in Japan 1969, COSEL is one of the world's leading designers and manufacturers of high performance AC-DC Power Supplies, DC-DC Converters and EMI Filters. With quality, reliability & flexibility as our main focus, we pride ourselves on developing some of the

highest quality and most reliable products seen anywhere in the world today. The Cosel Group is a global company with sales offices throughout Japan, Asia, Europe and North America.



Programmable  
300W-1500W

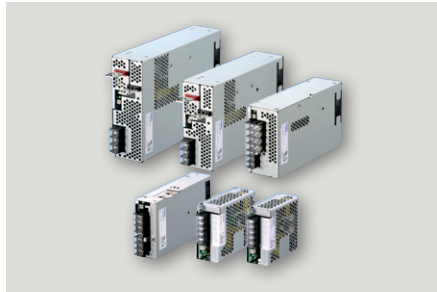

Enclosed  
10W - 10KW



Configurable  
300W - 1200W

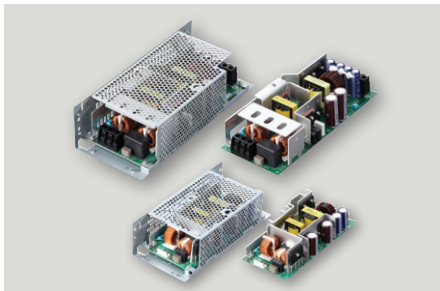

Open Frame  
10W - 300W

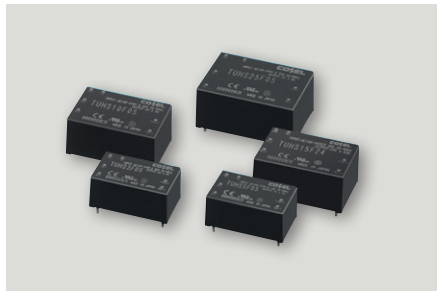

PCB AC/DC  
3W - 25W



PCB Power Modules  
50W-1200W



DIN-Rail  
30W - 480W

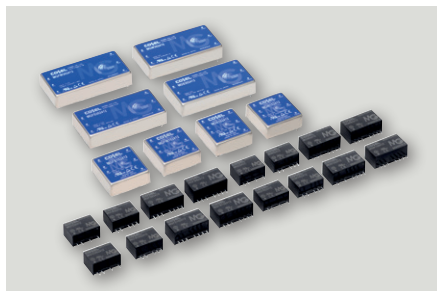

Low power series  
1.5W - 80W

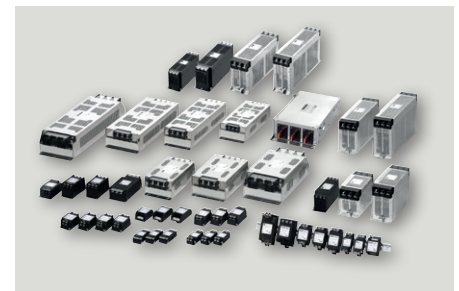

EMI filters

# Custom products



Rugged DC/DC Booster for diesel engine delivering constant voltage to the engine monitoring system during startup. The unit generates boosted voltage to compensate lower battery voltage during the ignition phase.



Diesel battery control unit, including battery switch controller (300A continuous, 600A peak) with load balancing. The unit includes remote control and design to comply with engine compartment requirements.

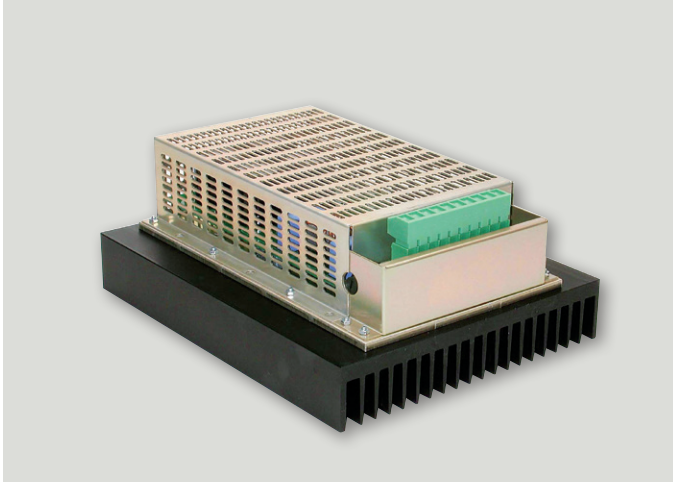

500W ruggedized AC/DC power supply for crane application. Single output 25.5V, input voltage range 115-230VAC.

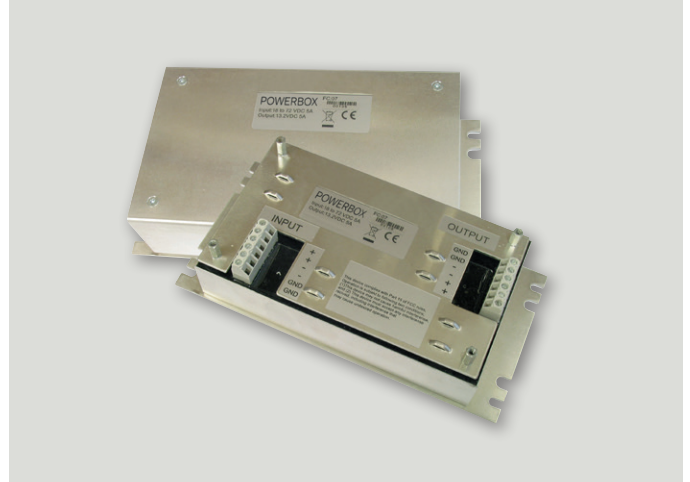

Ruggedized 60W DC/DC power supply for powering PC systems in automotive applications.





# Power solutions examples

## **Ruggedized DC/DC converter feeding a PC mounted on a fork lift**

The challenge: The customer is manufacturing advanced industrial PCs that are mounted on fork lifts, and used for warehouse management. The built in PC battery was discharged much faster than the battery feeding the fork lift. Tests had been made using standard DC/DC converters but they did not withstand the tough environmental stress occurring on a fork lift with solid wheels, crossing rail tracks in a warehouse, also exposed to fast temperature changes and sometimes to aggressive substances in the food or chemical industries. The other obstacle was that the DC/DC converters available on the market did not match all fork lift system voltages.

The solution: Powerbox developed a DC/DC converter family allowing that the industrial PC was fed from all types of fork lift batteries. The advantage is that the PC always could be operated when the fork lift was active. Powerbox did also handle the process of obtaining global safety and EMC approvals. The potted mechanics meant that it is capable of handling the mentioned rough environmental stress.

Added value: The customer was able to offer its customers, power solutions for all types of fork lifts. The proven ruggedised design did minimise the service need due to zero field defects.

## **Bus fleets modernization and passenger comfort**

The challenge: With the development of large cities and growing demand for inter-city exchanges, existing train networks are often insufficient on their own and require complimentary fleets of busses to enable passengers to reach destinations efficiently.

For passengers convenience and connectability while traveling, new vehicles are equipped with individual video systems, high speed internet access connection and equipment providing information and guaranteeing passenger safety. Such equipment is often installed in seats and requires stable and reliable power sources. Fleet operators are also requiring standardized DC/DC converters, in a range of 100W to 200W, which can be installed in confined spaces with limited height (below two centimeters) and only cooled by convection air flow.

The solution: We designed a standardised packaged 100W and 200W DC/DC converter, the ENA100 and ENA200, that took into consideration confined mechanical and thermal constraints. Using planar-technology, combined with a high efficiency conversion power-stage, the layout of the design was optimised for conduction cooling, including provisions for full protection and filtering to simplify installation and operation.

Added value: By incorporating highly integrated features within the design, we were able to offer products that could power a large range of electronics equipment applications in busses. Also, by utilising the same sized standard packaging for both the 100W ENA100 and 200W ENA200 units, systems can be easily upgraded when more power is required.

# About Powerbox

## **Who we are**

The combination of our extensive standard product range, our custom design capability, and our service offering, is truly unique. 40+ years of designing power supplies for demanding applications has built a rock solid experience. Our "Making the complex simple" business idea runs throughout our operation, from our customer interface and cooperation to how we design our products.

## **Improving your competitiveness**

The power solution chosen for any electronics has an impact on competitiveness. Function and reliability are given basics. Size, weight and audible noise might be important. Cost is always a consideration. Standards fulfillment can open up new markets. Time to market might be critical. Well executed supply chain management can generate savings. Aftermarket support has a lasting long term impact. The list goes on.

Our extensive experience and market awareness makes it simple to explain to us what you need. Together we define which power solution will serve your application the best.

## **Making the complex simple**

With our global presence we are close to you, and our knowledge and experience of working with so many different applications helps to make life easier for you. We can assist at all stages of product development, including evaluations, validations, and the writing of specifications. We aim for simplicity in design, referring both to lean design with fewer components and to a modular approach reusing proven circuits and building blocks, maybe with some modifications.

## **Quality assurance and follow-up**

Quality is an integrated part of everything we do. Our design process includes extensive testing, internal as well as external. Tests are also frequently run by our customers in their respective applications. In addition to the information we gain by tracking repairs and service requests, we also do regular quality follow up together with our customers, all to ensure a long and trouble-free life for our products. Powerbox is also certified by DNV according to ISO 9001:2008.

## **Manufacturing**

We manufacture at selected CEMs (Contract Equipment Manufacturer), where we apply rigorous process and quality requirements. We aim for long-term relationship with our manufacturing partners. A dedicated team for CEM Management and Quality Assurance work closely with them.

## **Caring for the environment**

At Powerbox we take an active role in protecting our environment. Our contribution includes:

Streamlined solutions and lean design using fewer components reduces material used. RoHS, WEEE and REACH are among the standards governing choice of materials.

High efficiency reduces energy consumption both directly by reducing losses and indirectly by reducing the need for cooling.

Energy efficient transportation and well developed use of online meetings are important elements in our determination to meet or exceed international standards by sustaining ISO-14001 compliance or the equivalent.

## **Providing peace of mind**

Even the best designed power solutions might require midlife support. Components involved in the design might be discontinued, or the application might be modified or changed, requiring changes in the power solution. In situations like this Powerbox' stability and endurance, and long term approach to customer relations, are true comforts.

## **About Cosel**

Established in Japan 1969, COSEL is one of the world's leading designers and manufacturers of high performance AC-DC Power Supplies, DC-DC Converters and EMI Filters. With quality, reliability & flexibility as our main focus, we pride ourselves on developing some of the highest quality and most reliable products seen anywhere in the world today. Our product range is aimed mostly at demanding applications within the Industrial, Factory Automation, Medical, Telecoms, Lighting, Audio/ Broadcast & Renewable Energy sectors. A flexible approach with full in-house design means we deliver products using the very latest technology meeting the growing demands of our customers.

# POWERBOX offices

## **POWERBOX Europe HQ**

Västberga Allé 36A, 5tr  
126 30 Hägersten  
Sweden

Phone: + 46 158 703 00  
Email: info.se@prbx.com

## **POWERBOX Benelux**

Phone: + 31 76 501 58 56  
Email: info.nl@prbx.com

## **POWERBOX China**

Phone: + 86-512-57720011  
Email: info.cn@prbx.com

## **POWERBOX Denmark**

Phone: + 46 158 703 00  
Email: info.dk@prbx.com

## **POWERBOX Finland**

Phone: + 358 2 273 6100  
Email: info.fi@prbx.com

## **POWERBOX France**

Phone: + 33 (0)1 64 11 43 43  
Email: info.fr@prbx.com

## **POWERBOX Germany**

Phone: +49 421 949 30 0  
Email: info.de@prbx.com

## **POWERBOX Italy**

Phone: + 39 02 998 88 45  
Email: info.it@prbx.com

## **POWERBOX Norway**

Phone: + 47 67 16 44 00  
Email: info.no@prbx.com

## **POWERBOX Spain**

*Barcelona Office*  
Phone: + 34 93 2969080  
Email: info.es@prbx.com

*Madrid Office*  
Phone: + 34 91 3260436  
Email: info.es@prbx.com

## **POWERBOX United Kingdom**

Phone: +44 7899 807 707  
Email: info.uk@prbx.com

## **POWERBOX North America**

Phone: +1 (603) 361-4509  
Email: info.us@prbx.com

## **Find more about PRBX**

### **Offices locations:**

[www.prbx.com](http://www.prbx.com)

# COSEL offices

## **COSEL Head Office**

1-6-43 Kami-Akae Machi,  
Toyama City, Toyama Prefecture,  
930-0816, Japan  
<https://en.cosel.co.jp>

## **COSEL ASIA LTD.**

Room 601, 9 Chong Yip Street,  
Kwun Tong  
Kowloon, Hong Kong, China  
[www.coselasia.com](http://www.coselasia.com)

## **COSEL EUROPE GmbH**

Lurgiallee 6-8,  
60439 Frankfurt am Main,  
Germany  
[www.coseleurope.eu](http://www.coseleurope.eu)

## **COSEL USA INC.**

2055 Gateway Place, Suite 240  
San Jose, CA 95110  
USA  
[www.coselusa.com](http://www.coselusa.com)

