



The silent power of supercapacitors

From harvesting energy through to power plants, the use of power electronics is everywhere and there isn't an application that doesn't require power. The power electronics industry is very dynamic and many new technologies have made the impossible, now possible. In the unceasing quest to increase performance levels, reliability and sustainability, new components and technologies such as Wide Bandgap Semiconductors and Digital power management are receiving the hype, getting a lot of attention and coverage. However, hiding in the shadows there is a component that is very important and intrinsically involved in many vital applications; **The Supercapacitor.**

Supercapacitors are almost everywhere, although perhaps because they are seen as passive components with a low-tech connotation, they are seldom on stage front. It is time to bring them back into the spotlight, so let's review the amazing story and technology behind the silent power of supercapacitors.

From Howard Becker to Elon Musk

In the early fifties when capacitors were made out of impregnated paper and mica, and electro-chemical, General Electric researched ways to increase their capacity to store and release higher energy levels, and to be able to absorb voltage distortions in electronics and in

top secret military applications. Research was conducted by Howard I. Becker and his team who on 14th April 1954 filed a patent for a 'Low voltage electrolytic capacitor' using a porous carbon electrode. On 23rd July 1957 the US2800616A patent was granted, opening the road for further innovation. Becker's invention was the beginning of a race between laboratories to convert the invention into a component capable of being mass manufactured (e.g. in 1958, Philips NV patented a process for the production of electrodes for electrolytic capacitors) with higher performance levels. **The modern electrolytic capacitor was born.**

Although the invention of the electrolytic capacitor was an important step forwards for the electronics industry, the capacity was still not enough to store higher levels of energy such as is required to stabilize an electricity network or to deliver extremely high energy levels as required by certain applications in the defense industry. It took another six year of research after Becker's patent for the Standard Oil Company's engineer Robert A. Rightmire to be granted on 29th of November 1966, the US3288641A patent for an 'Electrical energy storage apparatus' described as: "An electrical energy storage device for storing energy in electrostatic condition as double layers of electron-ions and proton-ions at co-acting interfaces..." **The supercapacitor was born...** Interestingly, it then took another 10 years for the invention to become a market reality.

Because of their capacity to store and release high amounts of energy in a very short time period, Electrical Vehicle (EV) research on high performance supercapacitors intensified, and the number of inventions and patents sky-rocketed. The foremost application in EVs was to store the energy generated when decelerating and braking in order to re-use that energy to power the engine when accelerating. The potential of the supercapacitor awakened attention in March 2011 at the Cleantech Forum in San Francisco when regarding the future of electric vehicles Elon Musk said, "If I were to make a prediction, I'd think there's a good chance that it is not batteries, but super-capacitors that will power the future of EV." Just to remind ourselves, Musk originally came to California to study high-energy-density capacitor physics at Stanford. His speech started a lot of speculation about the potential of supercapacitors, with the perception that they would be the solution to mass energy storage, eventually replacing batteries. The reality is a bit different though, from the timing of Becker and Rightmire's original

patents up to the present day, supercapacitor technology has progressed in a fair degree of 'behind the scenes' silence.

How does it work ?

As we all remember from school, a capacitor consists of two metal plates or conductors separated by an insulator such as air or a film made of plastic or ceramic. During charging, electrons accumulate on one conductor and depart from the other. Using normal manufacturing practices a conventional capacitor's energy storage is limited by the laws of physics and that is where Robert A. Rightmire's invention opened new avenues for high energy storage.

A supercapacitor cell basically consists of two electrodes, a separator, and an electrolyte. The electrodes are made up of a metallic collector that is the high conducting part, and of an active material (metal oxides, carbon and graphite are the most commonly used) that is the high surface area part. The two electrodes are separated by a membrane that allows mobility of the charged ions, but forbids electrical conductance. The system is impregnated with an electrolyte (Figure 01). The geometrical size of the two carbon sheets and of the separators are designed in such a way that they have a very high surface area. Due to its structure, the highly porous carbon can store more energy than any other electrolytic capacitor.

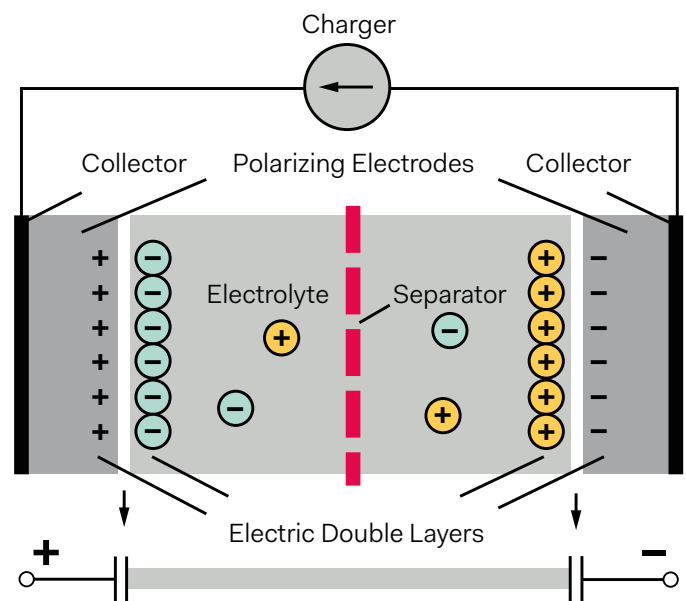

Figure 01 –Supercapacitor cell basically consists of two electrodes, a separator, and an electrolyte. (Source of the picture: PRBX).

When a voltage is applied to the positive plate, it attracts negative ions from the electrolyte, and when a voltage is applied to negative plate, it attracts positive ions from electrolyte. As a result, ion layers form on both sides of the plate in what is called a 'double layer' formation, resulting in the ions being stored near the surface of the carbon. This mechanism gives supercapacitors the ability to store and restore high energy within a very short time period.

The surface of the active part is the key to the supercapacitor's capacity and from what we know, increasing the surface area increases the capacity. What is particularly interesting and exciting in supercapacitor technology are the possibilities offered by the introduction of nanotechnologies. One example is to replace the conventional active carbon layer with a thin layer of billions of nanotubes. Each nanotube is like a uniform hollow cylinder 5nm diameter and 100um long, vertically grown over the conducting electrodes, and by using billions of them it is possible to reach extremely high density levels of capacity.

Will supercapacitors supersede batteries?

Following Elon Musk's speech at Cleantech Forum 2011, there has been a lot of interest in supercapacitors and for sure the potential offered by nanotechnologies is keeping high hopes that at some point in the future, supercapacitors might reach a point where they equal the performance of batteries. As can be seen in Figure 02 that portrays energy vs power density for different types of energy-storage devices, at the present time the performance levels of fuel-cells, batteries, ultracapacitors and conventional capacitors do not overlap. However, they are complimentary, and recent technological advancements are reducing the gap between batteries and supercapacitors. However, recent technological advancements are reducing the gap between batteries and supercapacitors.

Each of those technologies has their advantages and disadvantages, ones that power designers take into consideration when developing power systems. In Figure 03 we compare the key parameters of Li-ion batteries and supercapacitors, and it is obvious that one of the key benefits of the supercapacitor is its extremely high cyclability, meaning that it can be charged and discharged virtually an unlimited number of times, which is unlikely ever to be the case for the electrochemical battery having a defined, much shorter life cycle.

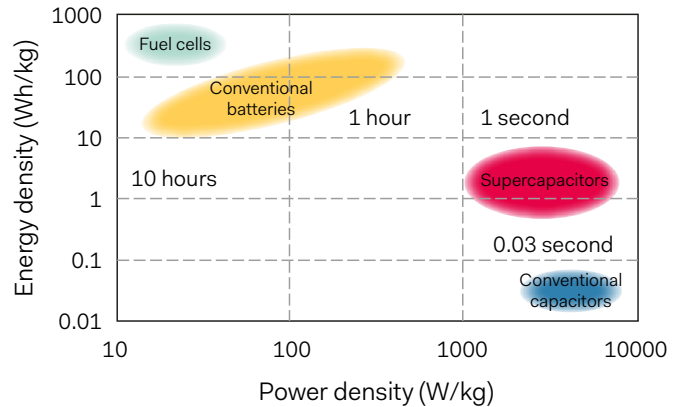

Figure 02 – Energy vs power density for different types of energy-storage devices. (Source of the picture: PRBX).

Feature	Li-ion Battery	Supercapacitor
Gravimetric energy (Wh/kg)	100 – 265	4 - 10
Volumetric energy (Wh/L)	220 – 400	4 - 14
Power density (W/kg)	1 500	3 000 – 40 000
Voltage of a cell (V)	3.6	2.7 - 3
ESR (mΩ)	500	40 - 300
Efficiency (%)	75 – 90	98
Cyclability (nb recharges)	500 – 1 000	500 000 – 20 000 000
Life	5 - 10 years	10 - 15 years
Self-discharge (% per month)	2	40 - 50
Charge temperature	0 to 45°C	-40 to 65°C
Discharge temperature	-20 to 60°C	-40 to 65°C
Deep discharge pb	yes	no
Overload pb	yes	no
Risk of thermal runaway	yes	no
Risk of explosion	yes	no
Charging 1 cell	complex	easy
Charging cells in series	complex	complex
Voltage on discharge	stable	decreasing
Cost per kWh	200 – 1 000 €	10 000 €

Figure 03 – Comparison of the key parameters between Li-ion batteries and supercapacitors. (Source of the picture: PRBX).

Ageing is also in favor of supercapacitors. Under normal conditions, from an original 100 percent capacity they only lose 20% in 10 years, which is way above the levels achieved by any battery. For systems designers having to power systems in harsh environments, supercapacitors will operate in very low to high temperatures without degradation, which we know is not the case for batteries. On the downside supercapacitors discharge from 100 to 50 percent in 30 to 40 days, whereas lead and lithium-based batteries self-discharge about 5 percent during the same period, but technology is improving daily and supercapacitors are becoming better and better.

POWERBOX

The silent power of supercapacitors

White paper 017

With the growing demand for renewable energy and issues relating to energy storage, there is a rising question about the reasoning behind building huge banks of Lithium Ion batteries. We all know that those batteries have a limited lifetime, but as well as consuming precious raw materials they're not easy to recycle and there's the associated environmental risks. This is where research is very interesting and the disclosure as presented by the Universities of Surrey and Bristol in February 2018 on the development of polymer materials is appealing. They achieved practical capacitance values of up to 4F/cm² when the industry standard is 0.3F/cm², and they are expecting to reach 11-20F/cm² in the near future. When such levels of capacity are achieved we will be able to talk about 180Wh/kg, which is similar to lithium ion batteries.

The level of research in supercapacitors is really impressive and the gap is closing. How fast that will happen remains unknown, but considering the number of patents filed, papers presented and levels industry interest, it shouldn't take too long.

In silence they do the job

Supercapacitors are almost everywhere and it is almost impossible to draw up an exhaustive list of applications. From the Shanghai bus experiment to run a fleet of buses powered only by supercapacitors to smart meters and harvesting energy, they are everywhere.

For sure it is their ability to sustain high charge and discharge cycles that makes them ideal for private and public electrical vehicles and machinery such as port-cranes to accumulate and re-use energy. But in many applications, when designers need peak power, they are there.

If you are an audiophile your audio amplifier might contain a supercapacitor bank able to deliver kilowatts of peak power to your bass loudspeaker when Ferruccio Furlanetto bellows out the deep notes in Don Quichotte. If you have a smart meter at home, it most probably contains a supercapacitor able to deliver peak power when transmitting stored data via the GPRS module. And again, if you are a technology geek following the Lamborghini 'Terzo Millennio' project, you will have noticed how important a role supercapacitors play in the motorization of this very special, electric powered sport car.

Safety is another benefit of supercapacitors and that is the reason why they are the first choice when backup or



Figure 04 –PRBX 29F supercapacitor energy peak and backup unit replacing battery in demanding applications. (Source of the picture: PRBX).

peak power is required in a restricted environment. Critical applications operating in hostile or confined environments are strictly regulated in terms of chemical and other hazardous risks, reducing or forbidding certain type of batteries such as Lithium Ion. For safety reasons, those applications must have a power backup long enough to run alarms and safety shutdown processes. In such arduous conditions, conventional batteries are replaced by supercapacitor banks whose values could be from a few Farads to 200 Farads for general applications (Figure 04).

What's coming next?

As we have seen, supercapacitor technology is moving extremely fast. The challenges posed by the energy storage issue is most probably the area where we will see the more immediate benefits of nanotechnologies being implemented in supercapacitors.

One example to close this article is the very interesting research conducted by the University of Central Florida on combining distribution cable with the capacity of supercapacitors. Assistant professor Jayan Thomas of the NanoScience Technology Center has found a way to improve a regular copper wire to transform it into a supercapacitor cable. Based on nanowhisker technology it could transform the standard copper wire into a supercapacitor capable of storing and delivering large amounts of power.

So in some degree of silence supercapacitors are becoming the most promising component for the future. Many power designers are already implementing power solutions based on supercapacitors but considering how fast research takes place and the huge challenges that humanity faces due to climate change, one day in the not too distant future, supercapacitors will be the heart of modern power solutions.

About Powerbox

Founded in 1974, with headquarters in Sweden and operations in 15 countries across four continents, Powerbox serves customers all around the globe. The company focuses on four major markets - industrial, medical, transportation/railway and defense - for which it designs and markets premium quality power conversion systems for demanding applications. Powerbox's mission is to use its expertise to increase customers' competitiveness by meeting all of their power needs. Every aspect of the company's business is focused on that goal, from the design of advanced components that go into products, through to high levels of customer service. Powerbox is recognized for technical innovations that reduce energy consumption and its ability to manage full product lifecycles while minimizing environmental impact. Powerbox a Cosel Group Company.

PRBX white paper 017 EN Rev B
2019.02.14



Patrick Le Fèvre
Powerbox Chief Marketing
& Communication Officer

About the author

Chief Marketing and Communications Officer for Powerbox, Patrick Le Fèvre is an experienced, senior marketer and degree-qualified engineer with a 25-year track record of success in power electronics. He has pioneered the marketing of new technologies such as digital power and technical initiatives to reduce energy consumption. Le Fèvre has written and presented numerous white papers and articles at the world's leading international power electronics conferences. These have been published over 210 times in media throughout the world. He is also involved in several environmental forums, sharing his expertise and knowledge of clean energy.

For more information

Visit www.prbx.com
Please contact Patrick Le Fèvre, CMCO
+46 (0)158 703 00